

REV	ECN No.	DESCRIPTION	DESIGN	DATE
AO		Release	蒋建银	2018.03.06

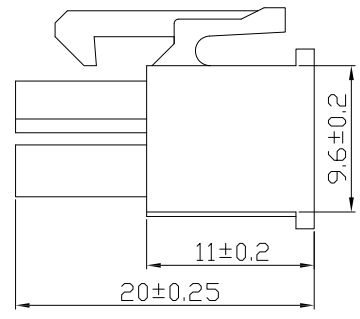
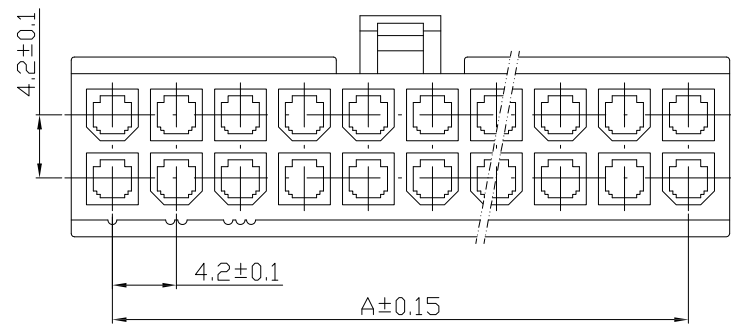
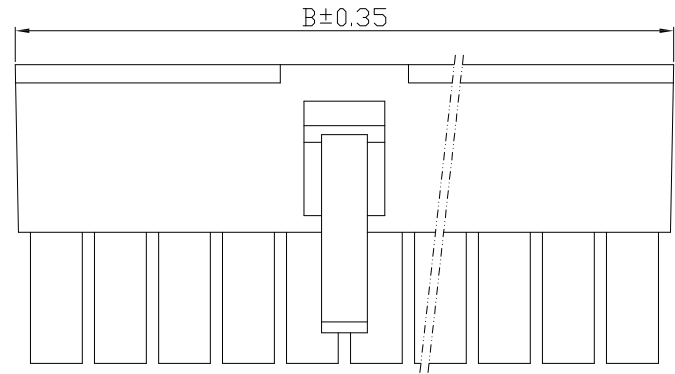

主要技术参数 Main Specifications

线数 (Poles): 02 to 24
 接触电阻 (Contact resistance): $\leq 20m\Omega$
 绝缘电阻 (Insulation resistance): $\geq 1000M\Omega$
 额定电压 (Rated voltage): 300 V AC DC
 额定电流 (Rated current): 9.0A AC DC
 耐电压 (Withstand Voltage): 1500V AC/minute
 温度范围 (Temperature Range): $-25^{\circ}C \sim +85^{\circ}C$

C4201P-2-A0T-P**

PART No. _____		PACKAGING: P=PE
No. OF CIRCUITS: _____		PLASTIC MATERIAL: A0T=PA66(Transparent)
201~212		

Circuits	Dimensions (mm)		Circuits	Dimensions (mm)	
	A	B		A	B
201		5.60	207	25.20	30.80
202	4.20	9.80	208	29.40	35.00
203	8.40	14.00	209	33.60	39.20
204	12.60	18.20	210	37.80	43.40
205	16.80	22.40	211	42.00	47.60
206	21.00	26.60	212	46.20	51.80

C	B	A	ITEM	COMPONENT	Q'TY	MATERIAL	FINISH
	CONTACT						
	HOUSING				1 PCS	PA66	COLOR:Transparent,UL94-V2

东莞市高迪电子有限公司
DONG GUAN GAO DI ELECTRONICS CO., LTD

TITLE: C4201P
4.2mmPITCH Housing

PART NO.:
C4201P-2**-A0T-P

DWG NO.:
GCCP-0678

SCALE: 1 : 1

SHEET: 1 / 1

X.±0.5	X.±5'	USE: CUSTOMER	APPD: 邵敬和
.X±0.3	.X±2'		
.XX±0.25	.XX±1'		
--	--	CHKD: 田峰	DR: 吴丹平
UNITS: mm			

A | B | C | D | E | F

REV	ECN No.	DESCRIPTION	DESIGN	DATE
AO		Release	吴丹平	2017.04.27

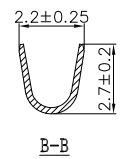
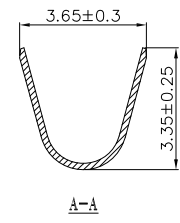
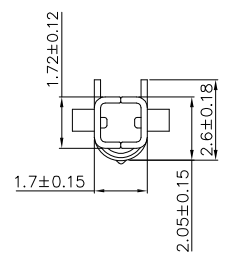
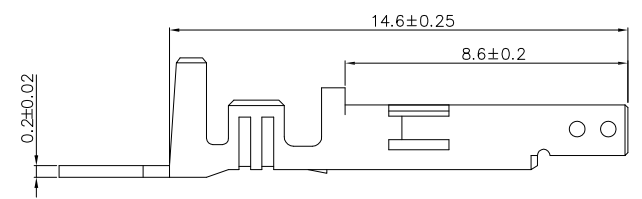
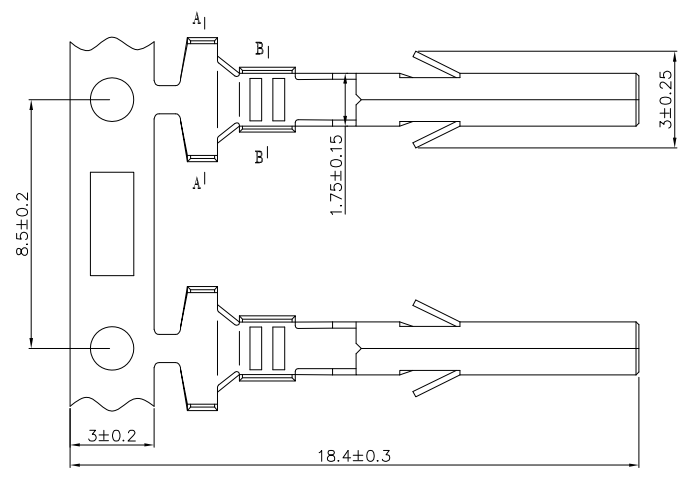

主要技术参数 Main Specifications

线数 (Poles): 02 to 24
 接触电阻 (Contact resistance): $\leq 20m\Omega$
 绝缘电阻 (Insulation resistance): $\geq 1000M\Omega$
 额定电压 (Rated voltage): 300 V AC DC
 额定电流 (Rated current): 9.0A AC DC
 耐电压 (Withstand Voltage): 1500V AC/minute
 温度范围 (Temperature Range): $-25^{\circ}C \sim +85^{\circ}C$
 适用线规 (Applicable wire): AWG #24 to #20

ITEM	COMPONENT	Q'TY	MATERIAL	FINISH
C				
B	CONTACT			
A	HOUSING	1 PCS	PhosphorBronze	Sn-plated
 东莞市高迪电子有限公司 DONG GUAN GAO DI ELECTRONICS CO., LTD				
TITLE: C4201PT端子				PART NO.:
X.±0.5	X.±5'	USE:	CUSTOMER	
.X±0.3	.X±2'	APPD:	邵敬和	
.XX±0.25	.XX±1'	CHKD:	田峰	
--	--	DR:	吴丹平	
UNITS: mm		SCALE	SHEET	
		1 : 1	1 / 1	

REV	ECN No.	DESCRIPTION	DESIGN	DATE
AO		Release	蒋建银	2018.03.06

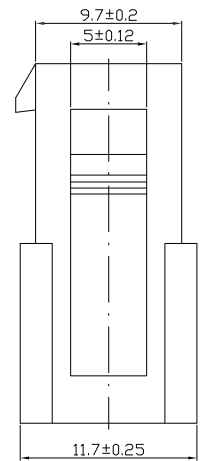
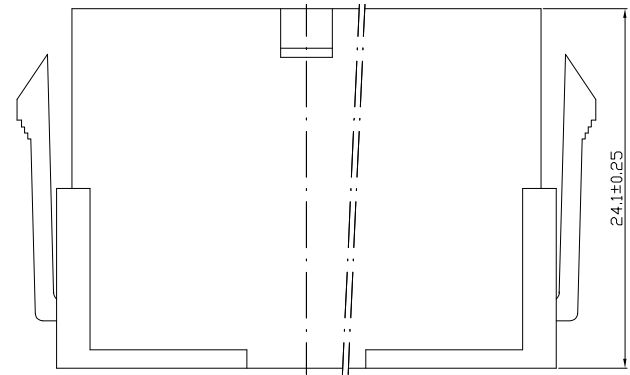
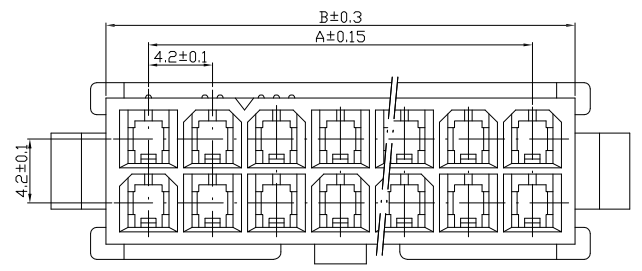

主要技术参数 Main Specifications

线数 (Poles): 02 to 24
 接触电阻 (Contact resistance): $\leq 20m\Omega$
 绝缘电阻 (Insulation resistance): $\geq 1000M\Omega$
 额定电压 (Rated voltage): 300 V AC DC
 额定电流 (Rated current): 9.0A AC DC
 耐电压 (Withstand Voltage): 1500V AC/minute
 温度范围 (Temperature Range): $-25^{\circ}C \sim +85^{\circ}C$

C4201R-2-AOT-P**

PART No. _____		PACKAGING: P=PE
No. OF CIRCUITS: _____		PLASTIC MATERIAL: AOT=PA66(Transparent)
201~212		

Circuits	Dimensions (mm)		Circuits	Dimensions (mm)	
	A	B		A	B
201		5.60	207	25.20	30.80
202	4.20	9.80	208	29.40	35.00
203	8.40	14.00	209	33.60	39.20
204	12.60	18.20	210	37.80	43.40
205	16.80	22.40	211	42.00	47.60
206	21.00	26.60	212	46.20	51.80

C	B	A	ITEM	COMPONENT	Q'TY	MATERIAL	FINISH
	CONTACT						
	HOUSING				1 PCS	PA66	COLOR:Transparent,UL94-V2

东莞市高迪电子有限公司
 DONG GUAN GAO DI ELECTRONICS CO., LTD

X.±0.5	X.±5'	USE: CUSTOMER
.X±0.3	.X±2'	APPD: 邵敬和
.XX±0.25	.XX±1'	CHKD: 田峰
--	--	DR: 吴丹平

TITLE: C4201R
4.2mmPITCH Housing

PART NO.:
C4201R-2**-AOT-P

DWG NO.:
GCCP-0678

SCALE 1 : 1	SHEET 1 / 1
----------------	----------------

REV	ECN No.	DESCRIPTION	DESIGN	DATE
A0		Release	吴丹平	2017.04.27

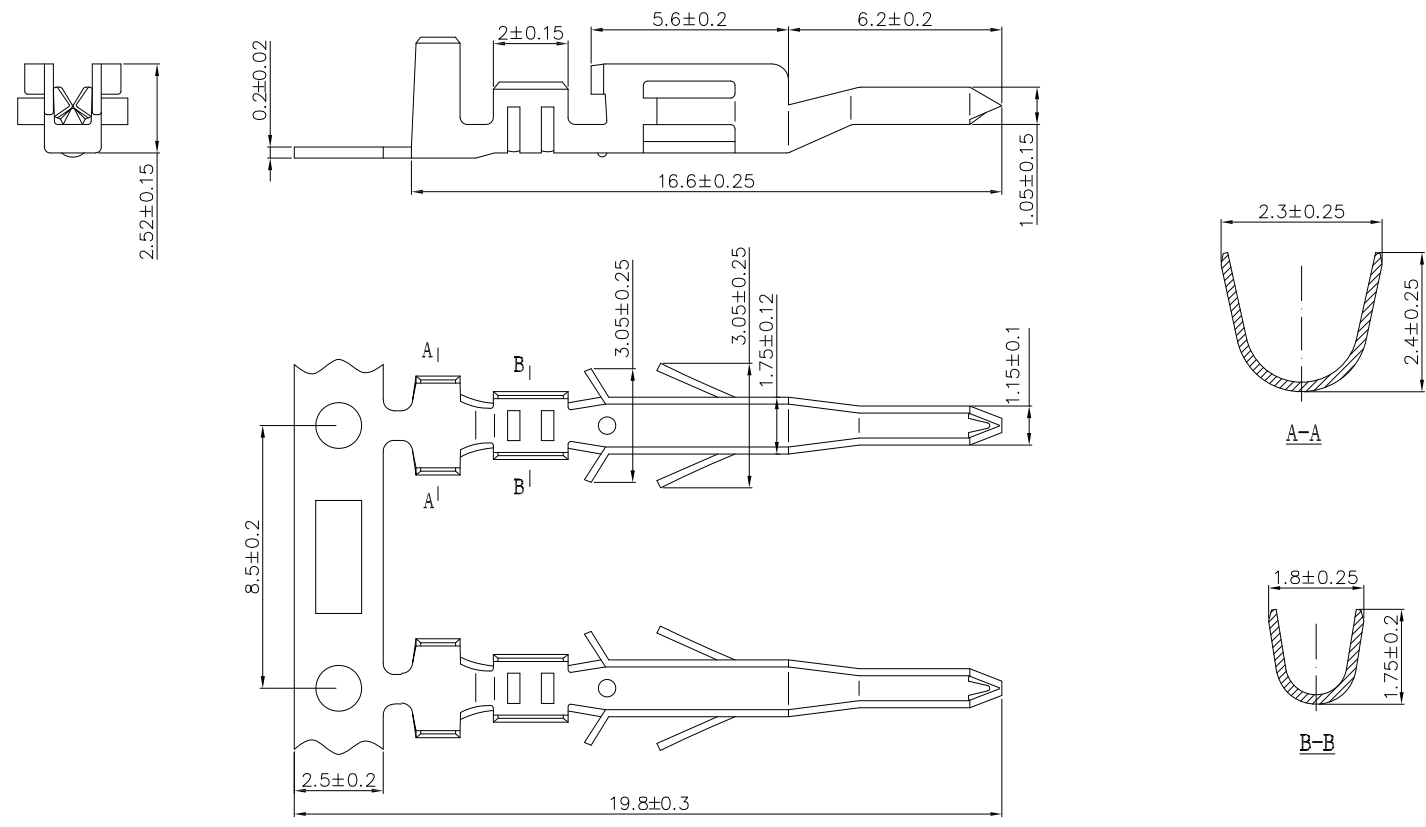

主要技术参数 Main Specifications

线数 (Poles): 02 to 24
 接触电阻 (Contact resistance): $\leq 20m\Omega$
 绝缘电阻 (Insulation resistance): $\geq 1000M\Omega$
 额定电压 (Rated voltage): 300 V AC DC
 额定电流 (Rated current): 9.0A AC DC
 耐电压 (Withstand Voltage): 1500V AC/minute
 温度范围 (Temperature Range): $-25^{\circ}C \sim +85^{\circ}C$
 适用线规 (Applicable wire): AWG #24 to #20

C					
B	CONTACT				
A	HOUSING		1 PCS	PhosphorBronze	Sn-plated
ITEM	COMPONENT		Q'TY	MATERIAL	FINISH
东莞市高迪电子有限公司 DONG GUAN GAO DI ELECTRONICS CO., LTD					TITLE: C4201R 端子
X.±0.5	X.±5'	USE:	CUSTOMER		PART NO.:
.X±0.3	.X±2'	APPD:	邵敬和		C4201RT-03端子
.XX±0.25	.XX±1'	CHKD:	田峰		DWG NO.:
--	--	DR:	吴丹平		GCDZ-0039
		UNITS:	mm		SCALE
					1 : 1
					SHEET
					1 / 1